

Top of the Pole Structure PN SLB

380098 • 06/2015

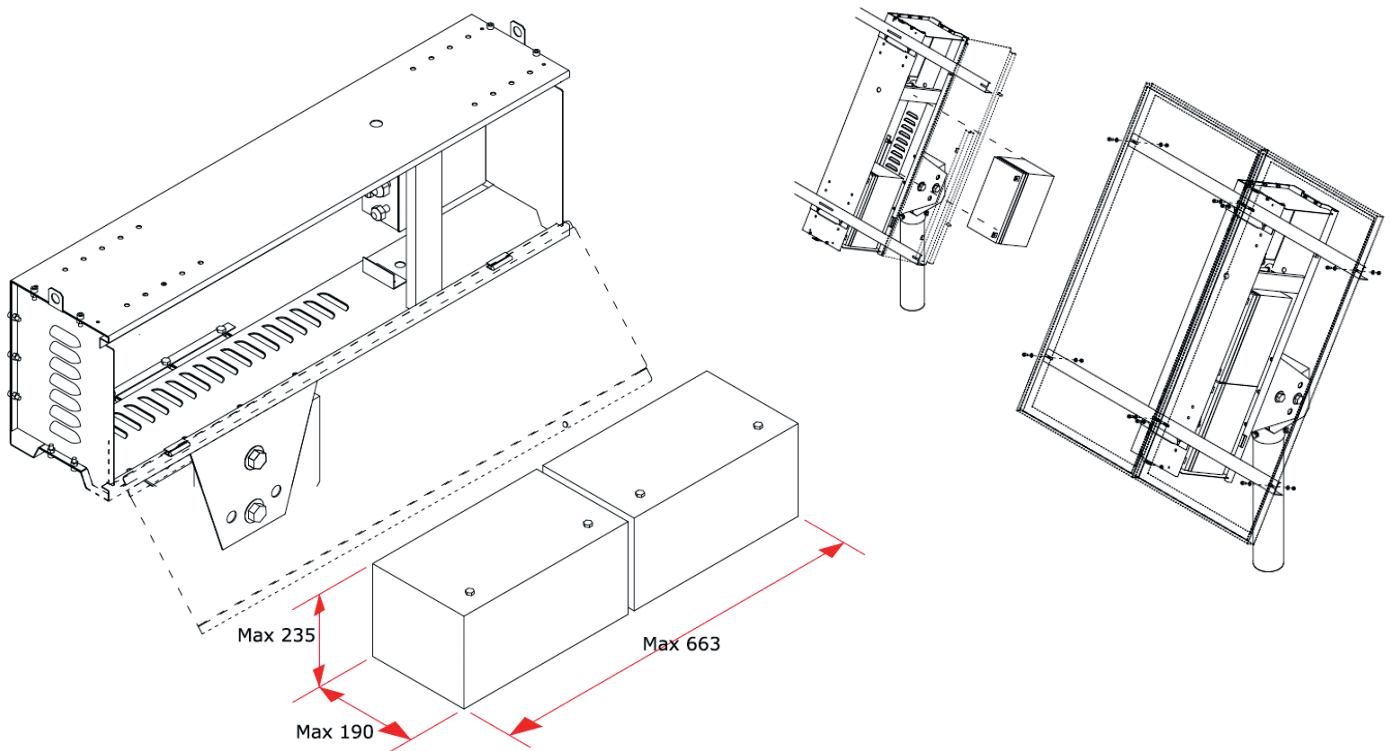

Technical Data	Technische Daten	Top of the Pole Structure PN SLB
Capacity for 12 V system	Kapazität für 12 V System	1 x 150 Ah (1,8 kWh)
Capacity for 24 V system	Kapazität für 24 V System	2 x 100 Ah (2,4 kWh)
Max. battery space	Maximaler Batterieraum	663 x 190 x 235 mm 2 x 330 x 190 x 235 mm
Corrosion Protection	Korrosionsschutz	protection class C4 galvanised 50 µm powder coat 110 µm
Tilt angle	Neigungswinkel	0° ... 80°
Max. module width	Max. Modulbreite	1360 mm
Max. module length	Max. Modullänge	1960 mm
Pole diameter	Mastdurchmesser	102 mm
Art.No.	Art.Nr.	380098