



DATA SHEET

grid | Xtreme VR

The HOPPECKE grid | Xtreme VR is the next generation of real pure lead (99.99% purity degree) AGM batteries. HOPPECKE has deliberately opted for better corrosion resistance and thus for a very long service life even in high-current applications and high ambient temperatures, such as in telecom applications.

Proven ESS technology = reduced life cycle costs (TCO)

The result of Enhanced Stability Standard (ESS) technology is an improved resilience against thermal runaway, better charge acceptance and more even voltage behaviour of the battery. This leads to a longer service life and reduced service costs: in summary optimised life cycle costs.



Extended operating temperature range = reduced air conditioning costs

The upper limit of the permissible operating temperature range has been increased from 45°C to an impressive 55°C. In combination with the dimensionally stable batteryhousing made of PC-ABS and the pure lead AGM technology, the grid | Xtreme VR is ideal for use in demanding high-temperature environments and reduces the cost of air conditioning the battery. The costs for air conditioning the battery room considerably.

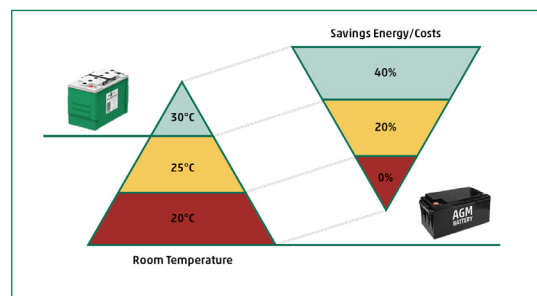

Patented, innovative safeguard-tec = lower operational costs

The innovative safeguard-tec for the top terminal types (optional) ensures dimensional stability throughout battery lifetime and at elevated ambient temperature. This allows installation in cabinets or on racks with limited demand for a continuous cost-intensive air-conditioning.

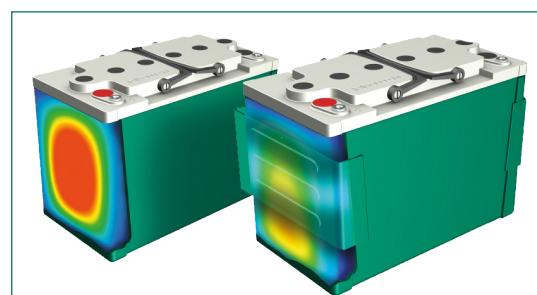



Construction

- High Performance Pure Lead grid electrodes for maximum corrosion resistance also under **elevated operating temperature**
- Active mass is designed for **maximum discharge performance** with good cyclability at the same time
- High-quality and low resistance microporous glass fibre separators combined with **ESS technology** ensures optimum charge carrier exchange and improves a **long-term stability**
- Fully isolated** HOPPECKE connector system
- Innovative plastic-overmolded dual-pole design with an **access for impedance measurements**
- 100% tested self-regulating pressure relief valve per cell to prevent interaction between cells of a block with backfire inhibiting for increased **operational safety**
- UL94 V-0** rated flame retardant PC-ABS material (halogen-free) - high heat, shock and vibration resistant
- 15 years** design life and optimised aging behaviour at high temperatures



Installation & Operation

- Suitable for standby parallel operation as well as partial cyclic applications
- Vertical as well as horizontal installation** on racks, in battery cabinets or in the grid | XtremeStack due to the robust folding handles integrated in the lid for easy assembly
- FT: **real front terminals** for an ease of installation and maintenance - no additional connectors needed
- TT: safeguard-tec optional available - **improves the overall performance** significantly
- Recommended charge float voltage: 2,3 Vpc @ 20°C (68°F) / 2,288 Vpc @ 25°C (77°F)
- Operating temperature range extremely wide from **-40°C to +55°C**
- Storage time** extended up to **2 years** for maximum project deployment flexibility
- Reduced maintenance: no refilling of distilled water is required
- Suitable for permanently high operating temperatures with short peaks up to 60°C



Standards

- Designed to be compliant with international standard **IEC 60896-21/22**
- Usage in applications where longest life and highest reliability are required. Therefore, classified as **"Very Long Life"** (>12 years) according to Eurobat Guide 2015
- UL recognized** component
- UL94 V-0 rated flame retardant PC-ABS material (halogen-free)
- Classified as non-spillable battery and approved as non-hazardous cargo for land, sea and air transportation in accordance with the requirements of **ADR / RID, IMDG and IATA**
- Exclusively manufactured in HOPPECKE certified production facilities in accordance with **ISO 9001, ISO 14001, ISO 50001 and ISO 45001**

Type overview **grid** | Xtreme VR

Capacity, dimensions and weights



Type	C ₁₀ /1,8 Vpc @20°C (68°F)	C ₈ /1,75 Vpc @25°C (77°F)	P _{15 min. /1,6 Vpc @25°C (77°F)}	P _{5 min. /1,6 Vpc @25°C (77°F)}	Length L*	Width W*	Height H	Weight	Terminal	Fig.
grid Xtreme VR 12-80	83 Ah	85 Ah	349 W/Z	687 W/Z	254 mm	174 mm	233 mm	~ 25,8 kg	M8 female	A
grid Xtreme VR 12-110	110 Ah	113 Ah	470 W/Z	921 W/Z	320 mm	174 mm	233 mm	~ 32,4 kg	M8 female	A
grid Xtreme VR 12-130	134 Ah	138 Ah	555 W/Z	971 W/Z	320 mm	174 mm	283 mm	~ 42,7 kg	M8 female	A
grid Xtreme VR 12-150	159 Ah	166 Ah	649 W/Z	1140 W/Z	359 mm	174 mm	283 mm	~ 46,3 kg	M8 female	A
grid Xtreme VR 12-170	180 Ah	187 Ah	746 W/Z	1341 W/Z	498 mm	174 mm	233 mm	~ 51,4 kg	M8 female	A

*) +3 mm length (L1) and +5 mm width (W1) using optional safeguard-tec



Type	C ₁₀ /1,8 Vpc @20°C (68°F)	C ₈ /1,75 Vpc @25°C (77°F)	C ₃ /1,7 Vpc @25°C (77°F)	C ₁ /1,7 Vpc @25°C (77°F)	Length L	Width W	Height H	Weight	Terminal	Fig.
grid Xtreme VR 12-100 FT 19"	96 Ah	100 Ah	92 Ah	78 Ah	404 mm	110 mm	264 mm	~ 30,2 kg	M8 female	B
grid Xtreme VR 12-100 FT 23"	105 Ah	109 Ah	100 Ah	86 Ah	563 mm	125 mm	200 mm	~ 33,9 kg	M8 female	B
grid Xtreme VR 12-150 FT	152 Ah	157 Ah	141 Ah	119 Ah	563 mm	110 mm	307 mm	~ 49,8 kg	M8 female	B
grid Xtreme VR 12-170 FT	167 Ah	172 Ah	155 Ah	131 Ah	563 mm	110 mm	307 mm	~ 50,2 kg	M8 female	B
grid Xtreme VR 12-190 FT	187 Ah	194 Ah	174 Ah	147 Ah	563 mm	125 mm	307 mm	~ 57,4 kg	M8 female	B
grid Xtreme VR 12-200 FT	201 Ah	209 Ah	190 Ah	158 Ah	563 mm	125 mm	322 mm	~ 61,2 kg	M8 female	B

*) -9,4 mm length (L1) for battery container

Fig. A

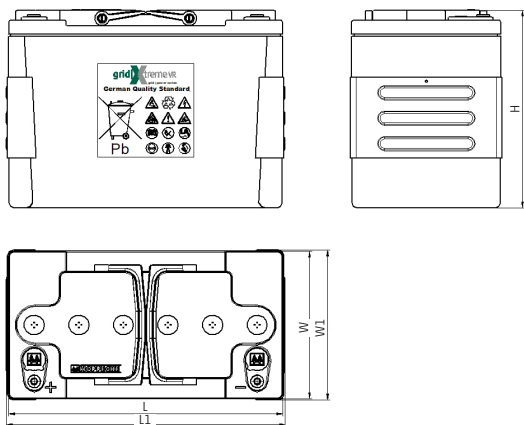
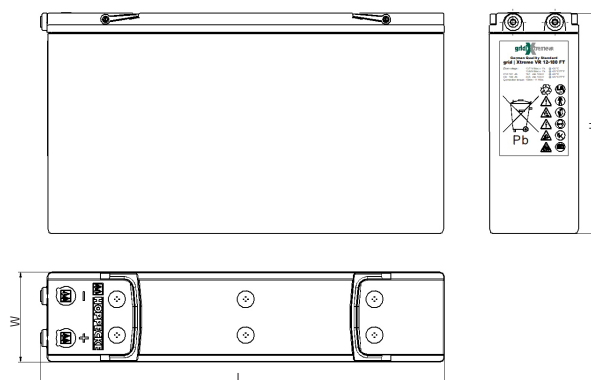

Fig. B



Tightening torque of terminal screw: 15 Nm - 133 lbf in

Applications **grid | Xtreme VR**

HOPPECKE's grid | Xtreme VR has been specially developed for



Data Center



Telecommunication

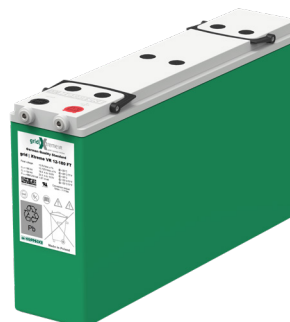

As a matter of fact, grid | Xtreme VR is versatile and may be used in other DC or AC industrial applications.

All of our cells and batteries should be installed, commissioned and operated in accordance with:

- HOPPECKE Operational Manual / Recommendations / Instructions
- International Standard IEC 62485-2 Safety requirements for secondary batteries and battery installations – Part 2: Stationary batteries
- Regional / National / Local Standards for the Environment

Optimal environmental compatibility - closed material cycle in certified recycling system

HOPPECKE Baterie Polska Sp. z o.o.
ul. Logistyczna 10
63-006 Śródka
Poland
Tel.: +48 61 64 65 000
Fax: +48 61 64 65 001
E-Mail: sbo@hoppecke.pl

HOPPECKE Batterien GmbH & Co. KG
Bontkirchener Straße 1
59929 Brilon
Germany
Tel.: +49 (0) 2963 61-374
Fax: +49 (0) 2963 61-270
E-Mail: reservpower@hoppecke.com

