



PV MODULE INSTALLATION MANUAL
CONSORT SOLAR CO., LTD

CONTENTS

Purpose of this Manual.....	2
Disclaimer.....	2
Safety & Transport.....	3
Mechanical Installation.....	7
Electrical Installation.....	14
Grounding.....	16
Bypass Diodes and Block Diodes.....	17
Maintenance.....	18

PURPOSE OF THIS MANUAL

- This manual applies exclusively to the solar photovoltaic module (here in after referred to as Module) of Wuxi Consort Science Technology Co., Ltd. (here in after referred to as CST). The contents of this manual involve the installation methods, operation safety and maintenance information of CST's Modules.
- Modules must be installed by professionals. Please read this manual carefully before installation. The installers must follow all the rules in this manual strictly as well as local requirements and regulations by law or authorized organizations.
- Before installing, the installer must be familiar with their mechanical and electrical requirements. Please keep this manual in a safe place for future reference (care and maintenance) and in case of sale or disposal of the Modules.

DISCLAIMER

- CST shall not be responsible for any loss arising from the installation, operation, use or maintenance of the Modules which is not complying with the guidance of this manual, including breakdown or damage of the Modules or any other expenses incurred.
- Any customer shall not get any patent or authorization of the patent when using the Modules, expressed or implied. Any infringement of patents or other rights of the third party, which may result from the use of the Module, is not within the responsibility scope of CST. The information in this manual is based on CST's knowledge and experience and is believed to be reliable, but such information including product specification (without limitation) and relevant suggestions do not constitute a warranty, expressed or implied.
- CST reserves the rights to change the manual, the Modules, the specifications or any other information of the Modules without prior notice.

SAFETY & TRANSPORT

General Detailed Rules

- Keep all the Modules and electrical connectors clean and dry before installation.
- Use both hands to carry Modules. Do not overlap Modules.
- Be cautious when carrying Modules. Slip-proof gloves are necessary.
- Use supportive disassembling tools when unpacking.
- The application level of CST module is Class A, which can be used in systems operating at greater than 50 V DC or 240W, where general contact access is anticipated.



Do not stamp on Modules or put weight on Modules.



Do not disassemble or drop Modules. Do not remove any nameplate or component of the module.



Do not use mirrors or magnifiers to concentrate sunlight onto Modules.



Do not lift the module by grasping the junction box or cable wire.



Do not use any sharp object with Modules.



Do not directly apply pressure on the glass surface or backsheet of Modules.



Do not touch the surface of the coated glass with bare hands.



Ensure all contacts and the operating environment are clean and dry.



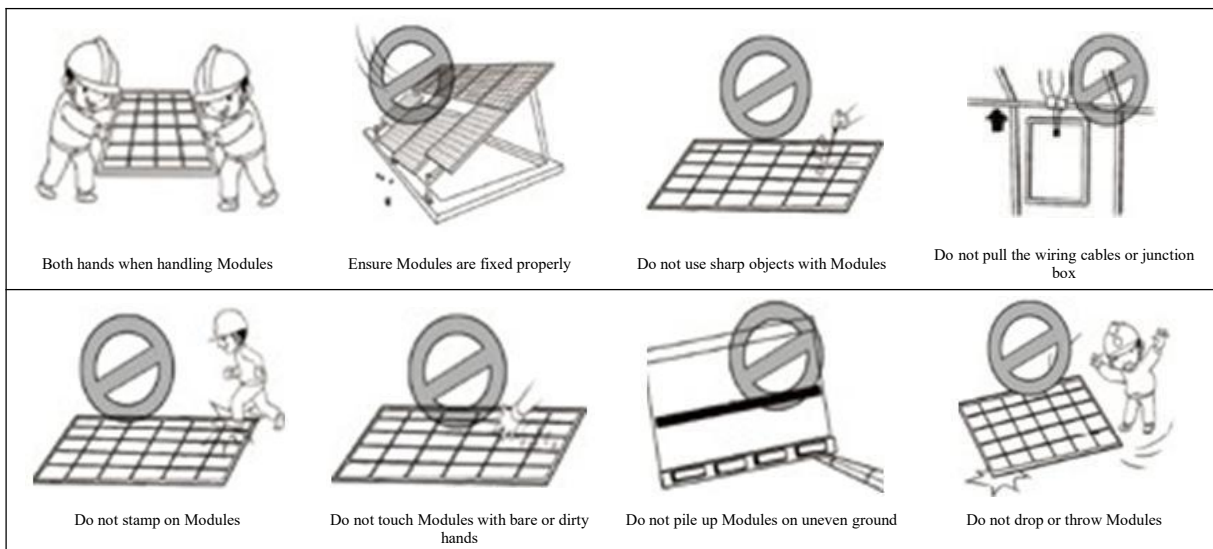

Module Carry and Installation Instruction



SAFETY & TRANSPORT

Description of Package Signs

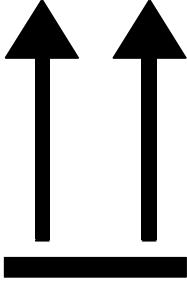
Before the operation, it is necessary to read carefully the unpacking instruction and outer packing box instruction, and carry out the operation as instructed.

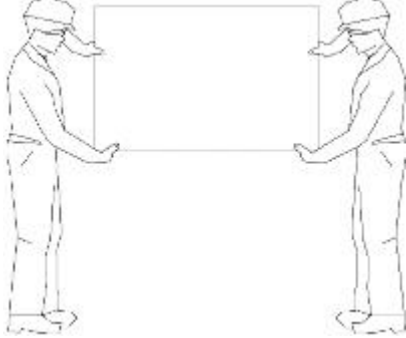
<p>1. DO NOT expose the module to rain or moisture.</p> 	<p>2. The Modules in the carton box are fragile. Handle with care.</p> 
<p>3. The package shall never be upside down during the transportation.</p> 	<p>4. It is prohibited to tramp on the packing box and module.</p> 
<p>5. During the stacking of the Modules, the outer packing box can be stacked not exceed the maximum layer allowed .(n=2 means it is allowed to stack for at most two layers.)</p> 	<p>6. One module shall be handled by two people together.</p> 

SAFETY & TRANSPORT

Unloading, Transportation and Storage

- When the Modules are delivered to the project site, the freight car shall be ready in the flat, even and open area for parking and unloading.
- Forklift unloading: Choose the appropriate carrying forklift according to the commodity weight, unload the Modules from the freight car and place them on flat ground.
- Unloading with a crane: Affix the lifting belt in the wood supporting frame buckle (Fig. 1, 2). It is allowed only to lift one pallet at a time. Before lifting, it is necessary to confirm whether the pallet and paper box are damaged and ensure that the lifting rope is robust and firm. When being lifted close to the ground, the paper box will be gently placed in a relatively flat position on the project site by two people, one on each side.



Figure 1 Wood Supporting Frame

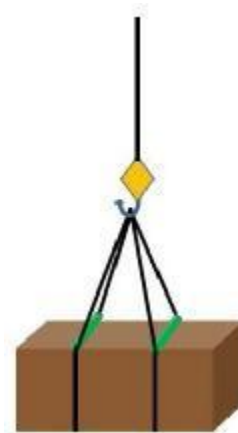

Figure 2 Lifting Schematics

- It is prohibited to stack the Modules in the project site.
- During the transportation at the project site, the Modules shall not be stacked, but only allowing for one layer in transportation.

SAFETY & TRANSPORT

- Storage in the project site warehouse:

Storage environment requirements: Humidity < 85%, temperature -20 ~+50 °C ; Modules statically stacked for ≤2 layers.

- Temporary storage at the project site: The Modules shall be stored in a dry, well-ventilated place. They shall not be stacked but shall be covered with waterproof cloth to prevent dampness in the Modules.

Unpacking description

1. In the outdoor unpacking process, it is prohibited to operate in rainy conditions;
2. If there is wind in the field, special attention shall be paid. Particularly in the event of heavy wind, it is recommended not to handle the module, and it is necessary to properly secure the unpacked Modules;
3. The working surface shall be such that the packing box can be placed in a stable, level position, avoiding being overturned;
4. During the unpacking, it is necessary to wear protective gloves, and avoid scratching the hands and leaving the fingerprints on the glass;
5. In the case of operation not according to the requirements or in the case of an unskillful operation, it will result in the fall-off of the protective corner in small amounts, which will be normal. The effect of the protective corner is to reduce damage due to external force during transport, and the fall-off of the protective corner will not influence the reliability of the Modules;
6. Before the unpacking, it is necessary to carefully check the product information on the carton box, and carefully read the unpacking instruction;
7. Every module shall be carried by two people. When carrying the module by two people, it is prohibited to pull the junction box.

MECHANICAL INSTALLATION

Location Selection

- Select suitable places to install Modules. The module in the north latitude region shall face south, and shall face north in the south latitude region.
- Install Modules at the places with sufficient sunlight and without shade at any time. If a module is shaded or even partially shaded, it will result in lower power output. A permanent or regular shade will cause module damage, which will result in the invalidity of product's limited warranty.
- Do not store, install or use Modules at the places where combustible gas is easily generated or gathering.
- The straight-line distance between the installation site and coastline shall not be shorter than 1 km unless there is a written approval from CST or an engagement specified in the contract.

Location Selection

- Modules in the same string should be installed at the same angle. Modules installed in different angles will receive different irradiation, which will cause current different. As a result, it will decrease the operation efficiency of the system.
- Please refer to Table 1 for the recommended mounting tilt angles of the Modules.

Local latitude	Mounting Tilt Angles
0°-15°	15°
15°-25°	Local latitude
25°-30°	Local latitude + 5°
30°-35°	Local latitude + 10°
35°- 40°	Local latitude + 15°
>40°	Local latitude + 20°

Table 1 Mounting Tilt Angle of Modules

MECHANICAL INSTALLATION



Installation requirements

- Ensure the module installation method and support system sufficiently robust, so that the Modules can undertake the preset loading conditions, the support installer or supplier shall provide necessary guarantee and other related certifications. The installation support system shall pass the inspection and test by the third-party test institution with the static mechanic analysis capability, and use the local national or international standards, such as DIN1055 or equivalent.
- The support structure shall be made of the durable, corrosion resistant and ultraviolet resistant materials.
- The module shall be firmly mounted on the support.
- Choose proper installation height of the photovoltaic support system, and ensure the lowest part of the module is high enough, to avoid being shaded by plant or being damaged by the flying sand. Or being covered by snow for a long time in winter.
- When the module is installed on the roof or the building, it is necessary to ensure that the roof structure is fixed firmly and will not be damaged by heavy wind or heavy snow, and the back of the module shall be well-ventilated to facilitate the cooling of the module (the minimum gap between the module and installation surface is 10cm).
- Considering the influence of linear thermal expansion of the module frame, the minimum distance between two Modules should not be less than 10mm.
- Ensure that the module backside will not contact the support or architectural structure even if there is the module surface is under the external pressure.
- It is required to observe the instruction guide and safety rules attached on the support.
- It is not allowed to drill the hole in the glass surface or frame of the module. otherwise ,the guarantee will be invalidated
- When to install the Modules on the roof, it is necessary to guarantee the roof structure is suitable for the module installation. And the installed modules should not be beyond the roof zone. Additionally, the roof area where it is penetrated by module installation shall be properly sealed to prevent the roof from water leakage.
- When the module is installed on the supporting column, it is necessary to ensure the supporting column and module installation structure is capable of withstanding the expected local wind.

MECHANICAL INSTALLATION

1、Framed Modules

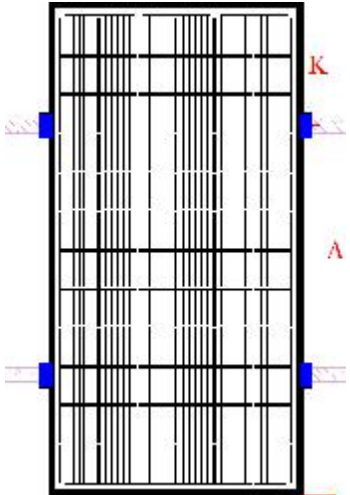
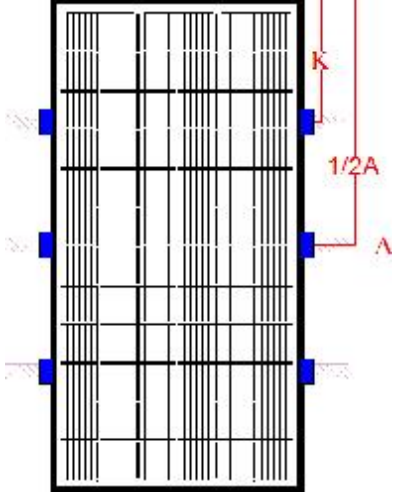
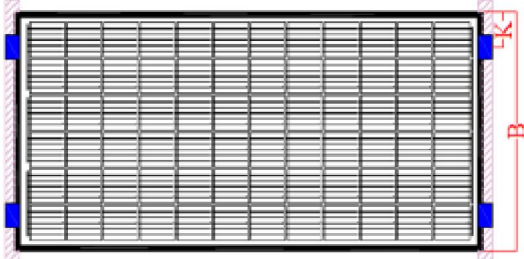
- Installation with the mounting clamp

Table 2 Installation Method			
	Installation Method B	Installation Method C	
Clamping on the long side			
	Installation Method D	Installation Method E	
Clamping on the short side			

Note: The length of the clamp $\geq 50\text{mm}$.

MECHANICAL INSTALLATION

Table 3 Installation method and load capacity

Installation Method		Installation Method B		Installation Method C		Installation Method D		Installation Method E	
Module Type	Module dimensions (mm)	Position of clamp K (mm)	Design load : downward / upward, $\gamma_m=1.5$ (Pa)	Position of clamp K (mm)	Design load : downward / upward, $\gamma_m=1.5$ (Pa)	Position of clamp K (mm)	Design load : downward/ upward, $\gamma_m=1.5$ (Pa)	Position of clamp K (mm)	Design load : downward/ upward, $\gamma_m=1.5$ (Pa)
CST-M8/72HXXX CST-M8/72BHXXX	2094*1038*35	473-573	3600/1600	—	—	25~260	1600/1600	25~260	1600/1600
CST-M8/60HXXX CST-M8/60BHXXX	1755*1038*35	392-492	3600/1600	—	—	25~262	1600/1600	25~262	1600/1600
CST-M10/78HXXX CST-M10/78BHXXX	2443*1134*35	554-654	3600/1600			233-233	1600/1600	233-333	1600/1600
	2465*1134*35	560-660				233-233		233-333	
CST-M10/72HXXX CST-M10/72BHXXX	2256*1133*35	514~614	3600 1600	—	—	233-333	1600/1600	233-333	1600/1600
	2279*1134*35	520~620		—	—	233-333		233-333	
CST-M10/66HXXX CST-M10/66BHXXX	2073*1133*35	468-568	3600 1600			233-333	1600/1600	233-333	1600/1600
	2094*1134*35	473-573				233-333		233-333	
CST-M10/60HXXX CST-M10/60BHXXX	1890*1133*35	422-522	3600 1600	—	—	233-333	1600/1600	233-333	1600/1600
	1908*1134*35	427~572		—	—	233-333		233-333	
CST-M10/54HXXX CST-M10/54BHXXX	1722*1134*35	380~480	3600 1600	—	—	233-333	1600/1600	233-333	1600/1600
CST-M12/60HXXX CST-M12/60BHXXX	2172*1303*35	493~593	3600 1600	—	—	275-375	1600/1600	275-375	1600/1600
CST-M12/66HXXX CST-M12/66BHXXX	2384*1303*35	546~646	3600 1600	—	—	275-375	1600/1600	275-375	1600/1600

Note: Test load = γ_m (safety factors) × design load

MECHANICAL INSTALLATION

- Installation with the mounting hole

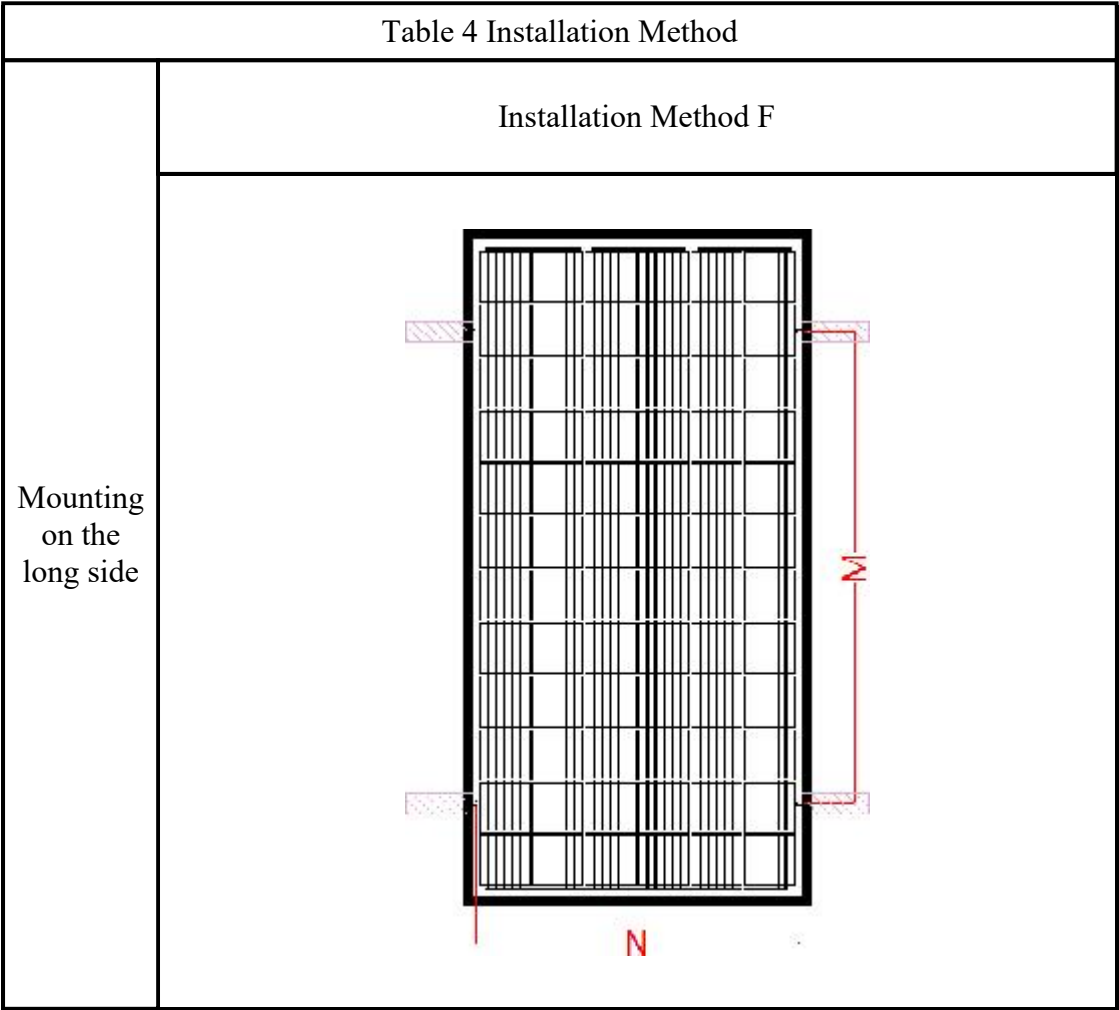

MECHANICAL INSTALLATION

Table 5 Mounting dimension and load capacity

Module Type	Module dimensions (mm)	Mounting distance M (mm)	Mounting distance N (mm)	Installation Method F
				Design load : downward/upward, $\gamma_m=1.5$ (Pa)
CST-M8/72HXXX	2094*1038*35	990	989	1600/1600
		1300	989	3600/1600
CST-M8/60HXXX	1755*1038*35	990	989	1600/1600
		1300	989	3600/1600
CST-M10/78HXXX	2443*1134*35	400	1084	1600/1600
		990	1084	3600/1600
		1400	1084	3600/1600
	2465*1134*35	400	1084	1600/1600
		990	1084	3600/1600
		1400	1084	3600/1600
CST-M10/72HXXX	2256*1133*35	400	1084	1600/1600
		990	1084	3600/1600
		1400	1084	3600/1600
	2279*1134*35	400	1085	1600/1600
		990	1085	3600/1600
		1400	1085	3600/1600
CST-M10/66HXXX	2073*1133*35	400	1084	1600/1600
		990	1084	3600/1600
		1400	1084	3600/1600
	2094*1134*35	400	1085	1600/1600
		990	1085	3600/1600
		1400	1085	3600/1600
CST-M10/60HXXX	1890*1133*35	400	1084	1600/1600
		990	1084	3600/1600
		1400	1084	3600/1600
	1908*1134*35	400	1085	1600/1600
		990	1085	3600/1600
		1400	1085	3600/1600
CST-M10/54HXXX	1722*1134*35	1150	1085	3600/1600
		1400	1085	3600/1600
CST-M12/60HXXX	2172*1303*35	400	1254	1600/1600
		1400	1254	3600/1600
CST-M12/66HXXX	2384*1303*35	400	1254	1600/1600
		1400	1254	3600/1600

Note: Test load = γ_m (safety factors) × design load

MECHANICAL INSTALLATION

The Modules may be installed and fixed with the following methods:

- Mounting hole system: Use the corrosion-resistant M8 bolt, for fixing with the installation support through the installation hole in the side frame of the module, as shown in Fig. 5.
- Clamping system: use proper clamp, and fix the module with the installation support, as shown in Fig. 6.

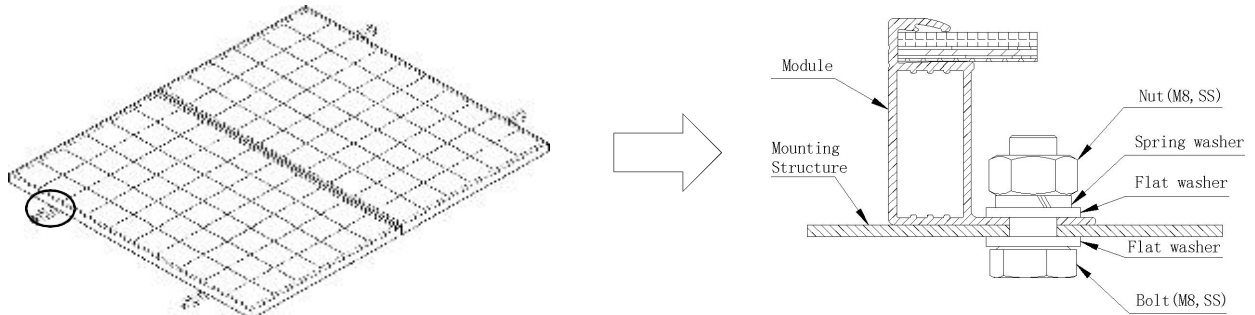

Figure 5 Mounting holes

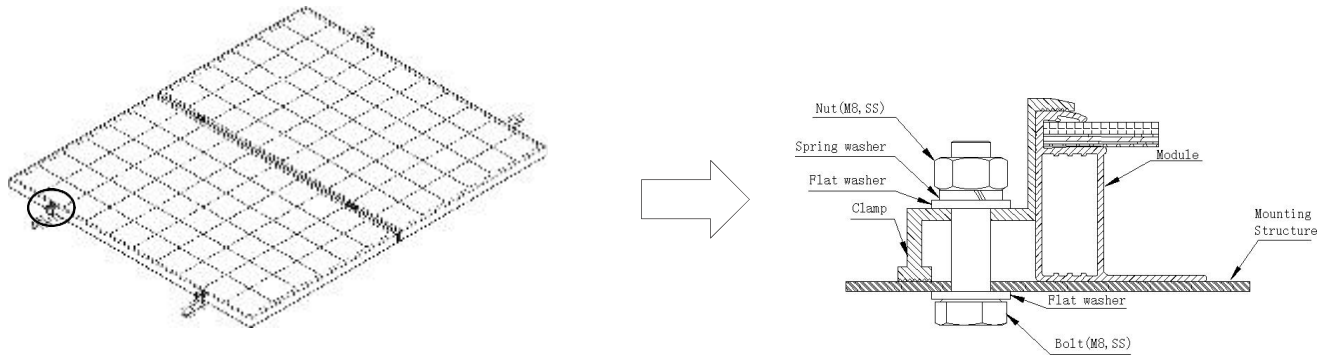

Figure 6 Mounting clamps

The mounting accessories recommended are listed below:

Bolt	Flat washer	Spring washer	Nut
Material: stainless	Steel material: stainless steel	Material: stainless steel	Material: stainless steel
Size: M8	Size: M8	Size: M8	Size: M8

The range of torque for screw tightening is 14N.m to 20N.m.

ELECTRICAL INSTALLATION

DC power generated by the photovoltaic system can be converted into AC power and fed into the grid. Policies on connecting renewable energy system to the grid vary from region to region. Consult senior system designer before designing the system. Generally, the system installation shall be formally approved by the local public sector.

General Installation

- Installation structure should be compatible with module, in order to avoid galvanic corrosion. Any defects caused by such corrosion will void the warranty.
- The DC-side system potential of the photovoltaic array includes the practice of floating ground, positive-pole grounding and negative-pole grounding according to the system requirements; and different cell technologies have different adaptability. In a power-station project, particularly the module of the crystalline silicon photovoltaic cells, too large an absolute value of the negative to the ground might cause potential induced degradation (PID). Consequently, it is appropriate to use the negative grounding system so that the potential of the circuit is positive. Consult the inverter manufacturer for details.
- It is forbidden for non-professionals to open the lock nuts of the connector. Make sure that the connectors are clean, dry and fully connected.
(A click sound should be heard when fully connected), otherwise it may lead to electric arc sparks which will damage the connector or cause a fire.
- Under normal conditions, a module is likely to experience conditions that produce more current and/or voltage than reported at standard test conditions, Accordingly, the values of ISC and VOC marked on the Module should be multiplied by a factor of 1.25 when to determining component voltage ratings, current ratings, fuse sizes, and size of controls connected to the PV output.
- Completely cover the Modules with an opaque material to prevent electricity from being generated during disassembling the conductors.
- It is not allowed to use the Modules in different models in the same solar photovoltaic system. When the Modules are connected in series, the voltage of every string shall not be higher than the maximum voltage of the system (as shown in Figure 8). Reference equation of the maximum number of the Modules in serial connection: maximum system voltage of the module/ (1.25* open-circuit voltage).
- When connected in parallel, the current output is equal to the sum of each string's current (as shown in Figure 9). Fuse is necessary for each module string. Take reference to the local regulation. Recommended maximum parallel Modules configurations: Fuse rating/ (1.25* short-circuit current).

ELECTRICAL INSTALLATION

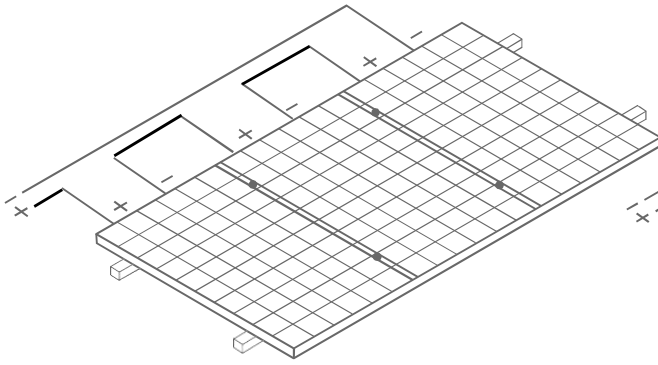

Figure 8 Connection in Series

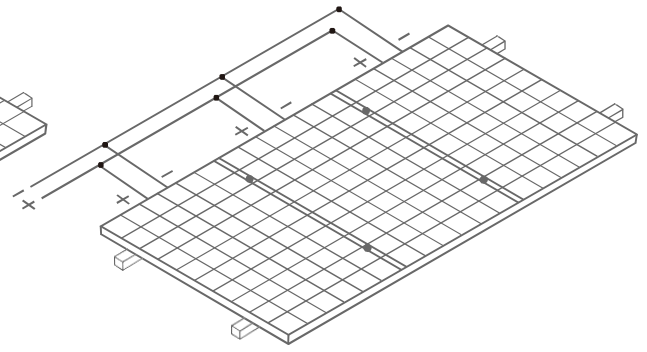

Figure 9 Connection in parallel

- Refer to the local regulations to determine the system wire size, types and temperatures.
- The cross section of the cables and the capacity of the connectors must be selected to suit the maximum system short circuit current (The recommended section area for a single piece of Module is 4 mm^2 , and the recommended rated current for the connector is greater than 10A), otherwise the cables and connectors shall be overheated under large current. Caution: The maximal temperature of the cable is $85 \text{ }^\circ\text{C}$ while the upper limited temperature of the connector is $105 \text{ }^\circ\text{C}$.
- Make sure the electric components such as the connectors and inverters are off-state during the installation. To reduce lightning damage, the loop area should be kept as small as possible when laying cables. It is recommended to use fuses in each string.

GROUNDING

➤ Grounding by cable

- The grounding bolts must be made of stainless steel and be used in the specified grounding holes. First, make the M3.5 stainless steel bolt pass through the spring washer, flat washer, cup washer (copper conductor with a diameter of 2.1 mm) and star washer, and then insert through the grounding hole, flat washer and spring washer on the frame. Finally, tighten with a M3.5 nut. Caution: The upper limited temperature of the conductor is 85°C. As for the installation, refer to Figure 10.

➤ Grounding by lugs

- All the module frames and mounting structures shall be grounded according to regional and national electricity regulations. Use recommended hardware to connect grounding cables and fasten to the Module frames.
- While using the metal structure, make sure the surface of the system have been electroplated to keep a good conducting circuit.
- Use suitable grounding conductors to connect the Module frame to the mounting structure. This can achieve proper grounding effects.
- The grounding conductor must be connected to ground via an appropriate grounding electrode. It is recommended to use lugs to connect the grounding cables. If it is only mechanically connected to a grounded module without bolts and nuts, the mounting system should be grounded as well.
- First, peel the grounding cable to a proper length without damage to the metal core. Then insert the peeled cable into the lug, tighten the screw. As shown in Figure 11, connect the lug to the aluminum frame with stainless steel bolts and connection components. The recommended tightening torque for M3 bolts is 2.3N•m.

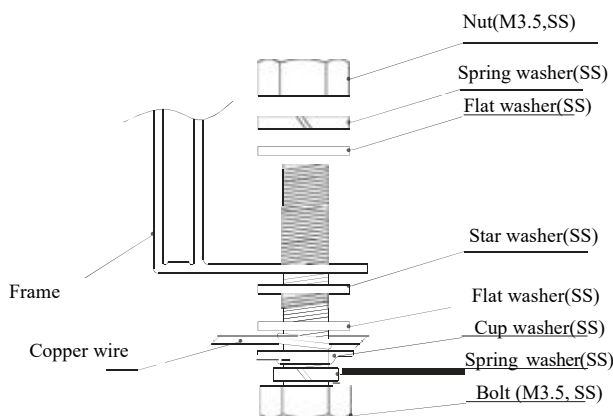

Figure 10

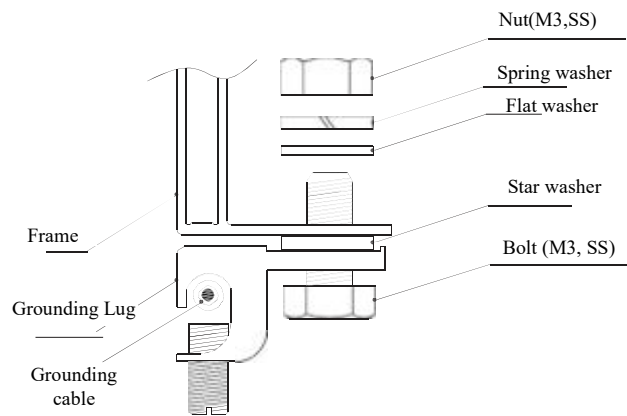

Figure 11

BYPASS DIODES AND BLOCK DIODES

In a system with two or more Modules connected in series, if part of a Module is shaded while the other part is exposed to the sun, a very high reverse current will go through the cells which have been partly or entirely covered and it will cause overheat on the cells, which may damage the Module. Using bypass diodes can protect Modules from this kind of risk. There are bypass diodes in junction boxes, which can reduce the effects of partial shadows. Do not privately disassemble the junction box to replace the diodes, even when the diodes are broken. This should be processed by the professionals.

In a system with batteries, if the controller doesn't have the function of backswing protection, block diodes installed between the battery and the Module can prevent the reverse current from damaging the Module.

MAINTENANCE

Normally, the Modules do not need repair. Follow the maintenance methods below to ensure the best performance of the Modules:

- In most conditions, the normal rainwater can keep the module glass clean. Clean the glass surfaces with wet soft sponge or cloth if necessary. Use mild non-abrasive cleaning agent to remove stubborn dirt.
- Do not try to clean a Module with broken glass or perforated backsheet. It will cause serious electrical shock. Take a regular inspection on grounding, mechanical and electrical connections every 6 months. Make sure all the Module connectors are connected, clean and without damage or corrosion.
- When disassembling the connectors, must make sure all the components are working well; otherwise the connector's shall be replaced. Damage on the connector will cause electronic leakage. The tightening torque of the nut should be $1.5 \text{ N} \cdot \text{m} - 3 \text{ N} \cdot \text{m}$.
- Use opaque material to completely cover the Modules during repair to avoid electric shock. When exposed to the sunshine, the Modules will produce high voltage. The repair work must be carried out by professionals.



Warning: Shut down the system before any electric repair. Improper maintenance may cause electric shock or fire.



CONSORT SOLAR CO., LTD.

Add : No.20, Jinqi Road, Yuqi Supporting Area, Huishan Economic Development Zone,
Wuxi, Jiangsu, P.R.China

Tel:+86 510 6822 3668

Fax:+86 510 6822 3668

Mob:+86 139 6171 3023

www.consortsolar.com